

Winch Carrier
 Installation Instructions
33600



Diagram 1

- Parts List:**
- 1 - Winch Carrier
 - 2 - License Plate Brackets
 - 4 - 1/2" Lock Washers
 - 4 - 1/2" Hex Nuts
 - 4 - 1/4" Hex Locking Nut
 - 4 - 1/4" x 3/4" HH Bolt
 - 8 - 1/2" x 1" Carriage Bolts

1. Remove the contents from the box and check for missing pieces or damage. If parts are missing or damaged, contact the original place of purchase. Read the instructions completely before beginning. Two people are strongly recommended for this install.

2. Installation of Winch Carrier: Using **Diagram 2** install the winch carrier between the uprights on grille guard. Use the (6) 1/2" x 1" carriage bolts to install the winch carrier. Place (1) 1/2" lock washer, (1) 1/2" flat washer and (1) 1/2" nut onto each carriage bolt. After Grille Guard has been tightened then tighten all carriage bolts.

3. If a front license plate is required in your state, attach the license plate brackets to the bottom of the winch carrier with the (2) 1/4 x 3/4" HH bolts, (2) 1/4" hex locking nuts as shown in **Diagram 3**.

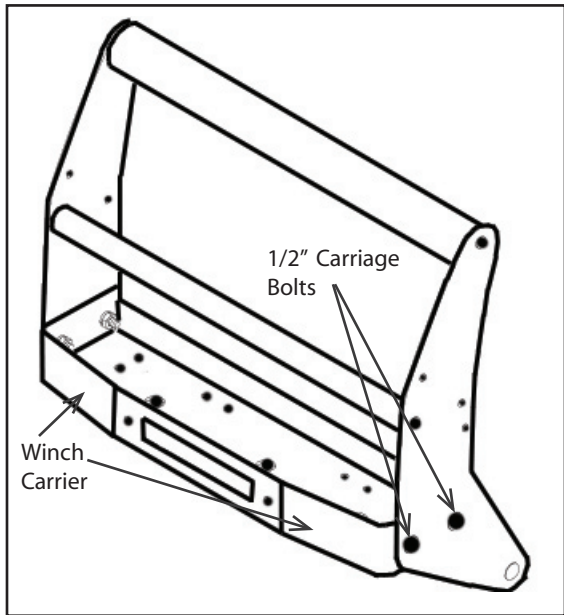

Diagram 2

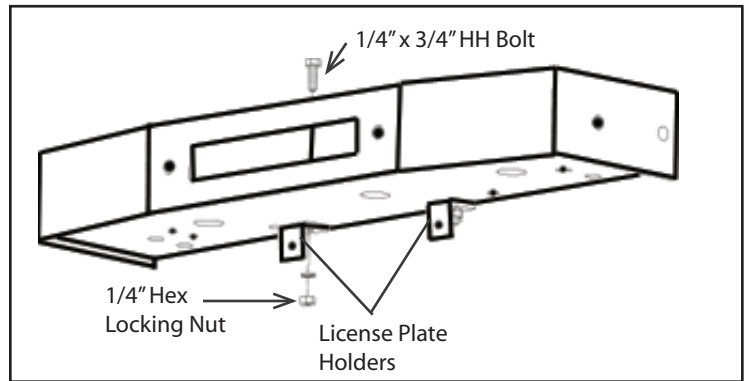

Diagram 3