



420 N. Grove, Richardson, TX 75081
 Tele: (800) 527 - 4345 Fax: (800) 442 - 5263
 Web site: www.goindustries.com
 E-mail: sales@goindustries.com

Rancher Grille Guard

Installation Instructions

45634 & 46634

Ford F-150 '99 - '03

Ford F-150 Heritage '04

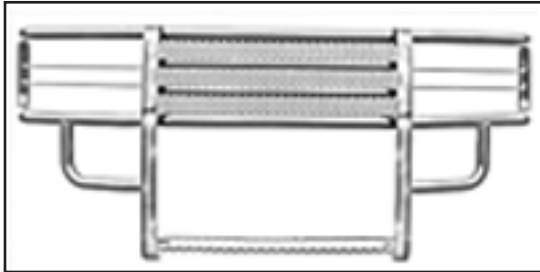

Diagram 1

Parts List:

- | | |
|-------------------------------------|------------------------------------|
| 1 - Rancher Guard Ring | 2 - 3/8" x 2 1/2" All-Thread Studs |
| 1 - Driver Top Bracket #434-5 | 2 - 3/8" Hex Nuts |
| 1 - Passenger Top Bracket #434-6 | 2 - 3/8" Lock Washers |
| 1 - Driver Bottom Bracket #633-7 | 2 - 1/2" x 4 1/2" HH Bolts |
| 1 - Passenger Bottom Bracket #633-8 | 6 - 1/2" Hex Nuts |
| 2 - Bottom Bracket #634-7 | 8 - 1/2" Lock Washers |
| | 10 - 1/2" Flat Washers |

1. Remove the contents from the box and check for missing pieces or damage. If parts are missing or damaged, contact the original place of purchase. Read the instructions completely before beginning. Two people are strongly recommended for this install.

2. **Install the Driver Top Brackets #434-5 and Passenger Top Bracket #434-6:** Using **Diagram 2**, insert the driver top bracket #434-5 between the bumper and the grille of the truck, starting at the outside edge of the bumper and fender. Behind the bumper at the bumper frame mount there is a rubber shield. Pull this free from the frame by removing the plastic rivet. This will allow proper placement of the top bracket. Position the top bracket at the center of frame. Place bracket over exposed ends of the factory bolts. Attach with (2) - 12mm jam nuts supplied, leaving loose at this time. Repeat above procedure to install the passenger top bracket #434-6.

3. On vehicles with tow hooks use bottom bracket #634-7. Using **Diagram 2**, remove front bolt to tow hook and loosen rear bolt. Place bottom bracket #634-7 between the frame and tow hook. Replace front bolt but do not tighten. End of bracket #634-7 will go through the down spoiler.

View of Frame With Bracket Placement

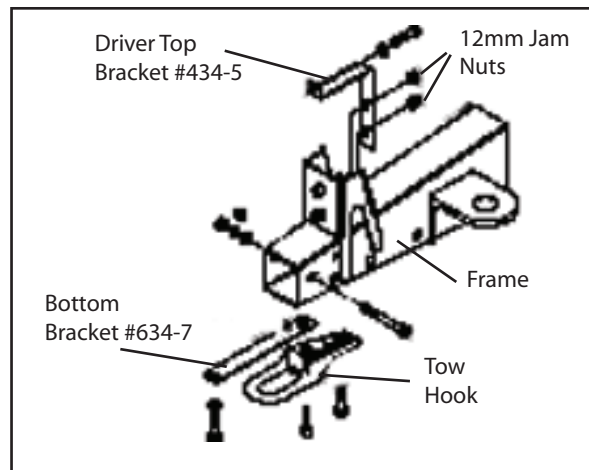

Diagram 2

4. **For vehicles without tow hooks use the driver bottom bracket #633-7 and passenger bottom bracket #633-8.** Using **Diagram 3**, place bottom bracket #633-7 against down spoiler and mark the spoiler for cut-out. Cut out marked area of spoiler. Place driver bottom bracket #633-7 against outside of frame. Place (1) 1/2" flat washer onto (1) 1/2" x 4 1/2" bolt put through bracket and through frame. Place (1) 1/2" flat washer, (1) 1/2" lock washer and (1) 1/2" hex nut onto the (1) 1/2" x 4 1/2" HH Bolt. Hand tighten nut at this time. Repeat above procedure to install the passenger bottom bracket #633-8.
5. **Attach the Grille Guard to the mounting brackets:** Using two people align the Grille Guard holes to the top brackets. Attach the Grille Guard to the top brackets using (2) 1/2" x 2" hex head bolts, (2) 1/2" flat washers, per hole in upright. Hand tighten all bolts at this time.
6. **Center the Grille Guard on the vehicle:** Center the Grille Guard on the vehicle. Tighten all bolts at this time insuring the Grille Guard remains centered on vehicle.

View of Frame With Bracket Placement

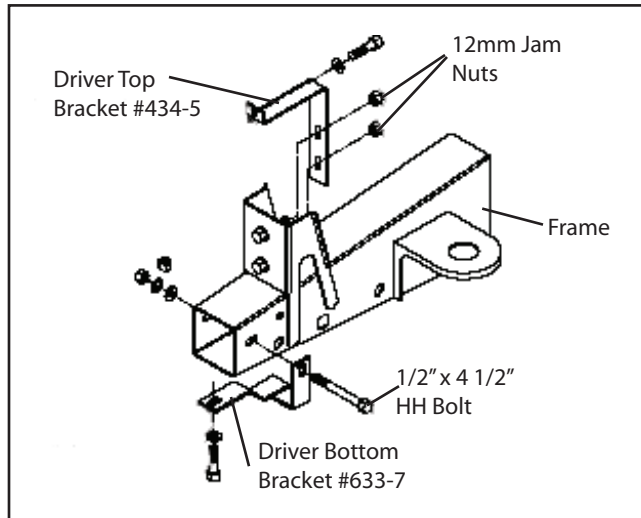

Diagram 3