

## Rancher Grille Guard

Installation Instructions

**45748 & 46748**

GMC 2500HD/3500 (New Body) '07 - '08

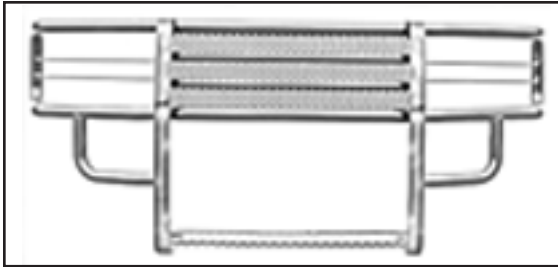

**Diagram 1**

**Parts List:**

1 - Rancher Grille Guard	8 - 1/2" x 1 1/4" HH Bolts
1 - Driver Top Bracket #485	8 - 1/2" Lock Washers
1 - Passenger Top Bracket #486	8 - 1/2" Hex Nuts
1 - Driver Bottom Brackets #487	16 - Flat Washers
1 - Passenger Bottom Bracket #488	

1. Remove the contents from the box and check for missing pieces or damage. If parts are missing or damaged, contact the original place of purchase. Read the instructions completely before beginning. Two people are strongly recommended for this install.

2. **Remove the Factory Radiator Cover and Factory Grille:** Open the hood on the truck. Using **Diagram 2**, locate the factory radiator cover. To remove the pop rivets, use a flat head screwdriver to pull up on the middle of the pop rivets. To remove the bottom part of pop rivet, place the screwdriver under the bottom and push up. Repeat this procedure to remove all pop rivets. Do not remove factory grille.

**View of Factory Grille and Radiator Cover**

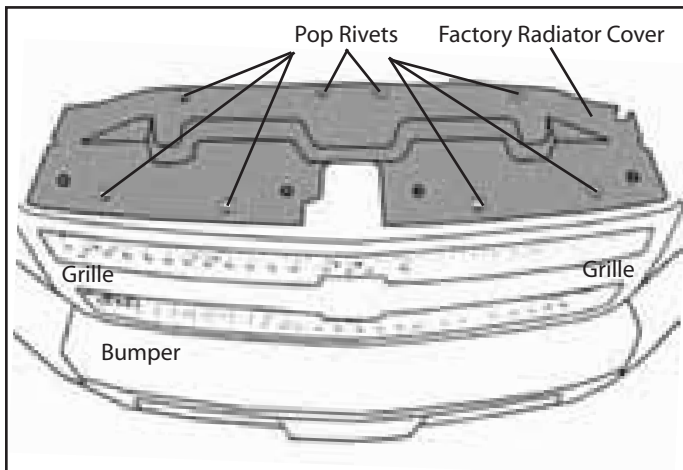

**Diagram 2**

**Rear View of Top Driver Bracket**

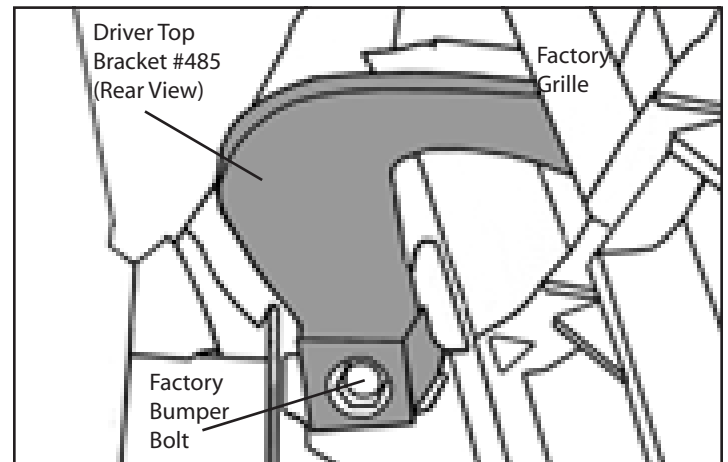

**Diagram 3**

3. **Install the Top Bracket #485 Driver Top Bracket and #486 Passenger Top Bracket:** Locate the Top Driver Bracket #485 for installation at this time.

A. Remove the factory bumper bolt as shown in **Diagram 3**. Slide top bracket #485 through factory grille as shown in **Diagram 4**. Place the Top Bracket #485 over the opening. Replace the factory bumper bolt through the top bracket and into the bolt hole opening. Hand tighten this bolt at this time.

B. Repeat step "A" above on the passenger side to install the Passenger Top Bracket #486.

**Front View of Top Driver Bracket**

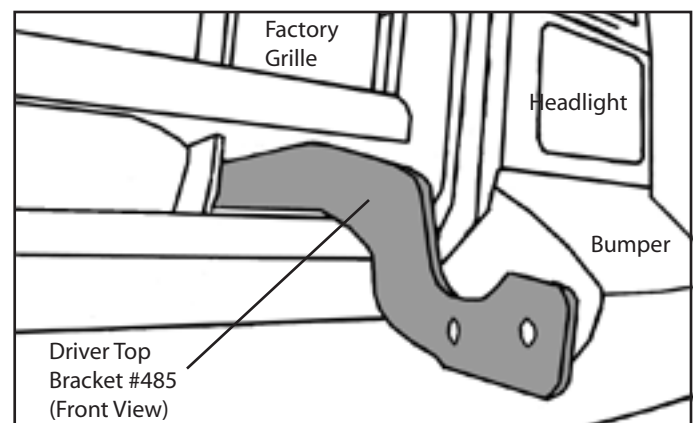

**Diagram 4**

420 N. Grove, Richardson, TX 75081  
 Tele: (800) 527 - 4345 Fax: (800) 442 - 5263  
 Web site: www.goindustries.com  
 E-mail: sales@goindustries.com

**Driver Bottom Bracket #487 Front View**

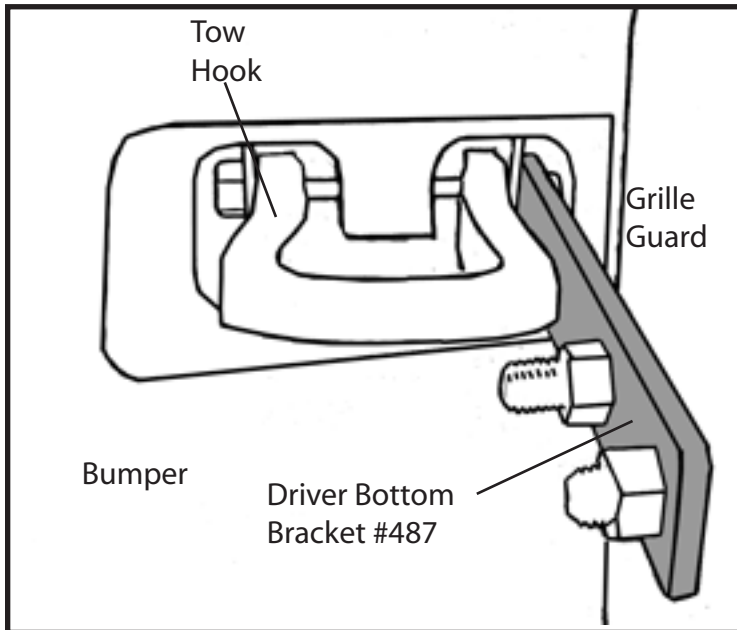

**Diagram 5**

**Bottom Bracket #487 Behind Bumper**

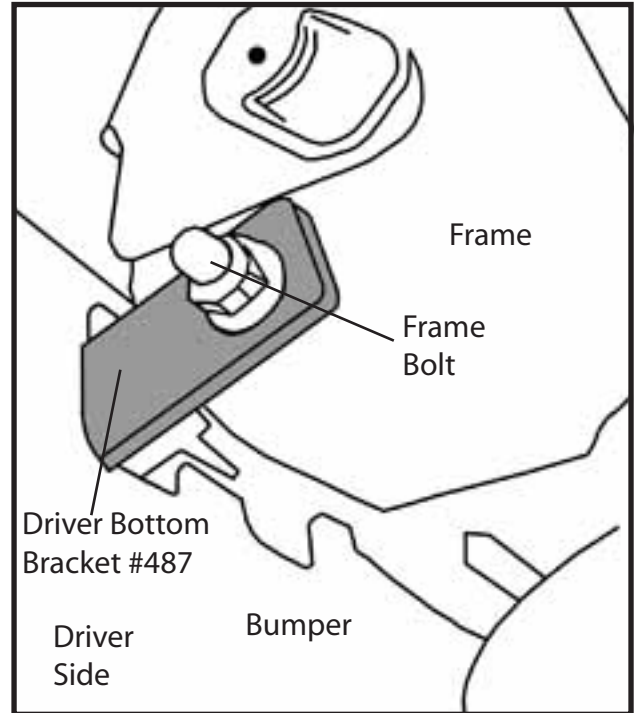

**Diagram 6**

6. **Install the Driver Bottom Brackets #487:** Locate the Driver Bottom Brackets #487 for installation at this time. On the driver side remove the nut on the frame bolt. Refer to **Diagram 6**. Place bracket up to bolt and replace nut. On passenger bottom bracket #488 the bolt will have to be removed. Place bracket onto bolt then replace through frame. Leave loose at this time. Refer to **Diagram 5** to install bracket to grille guard.
7. **Re-install Factory Grille and Factory Radiator Cover:** Re-install Factory Grille and Factory Radiator Cover. Align Factory grille with holes in vehicle, gently push Factory Grille until it clicks closed. Take radiator cover place over holes in vehicle. Replace pop rivets into vehicle.
8. **Attach the Grille Guard to the mounting brackets:** Using two people align the Grille Guard holes to the top brackets. Attach the Grille to the top brackets using (1) 1/2" x 2" hex head bolts, (2) 1/2" flat washers, (1) 1/2" lock washer and (1) 1/2" hex nut per hole in upright. Hand tighten all bolts at this time.
9. **Center the Grille Guard on the vehicle:** Center the Grille Guard on the vehicle. Tighten all bolts at this time insuring the Grille Guard remains centered on vehicle.