

Big Tex Grille Guard

Installation Instructions

77644 & 77644B

Ford Super Duty '11

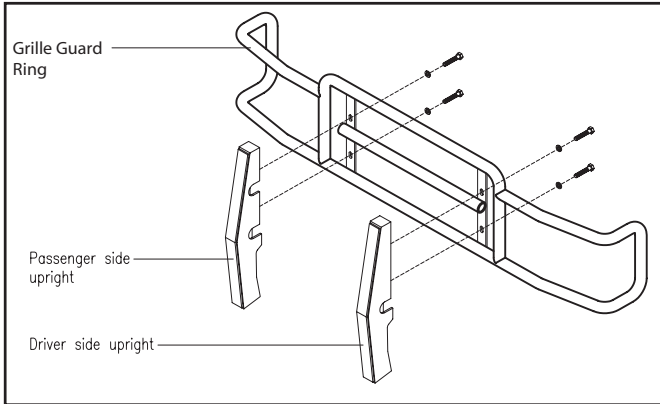

Diagram 1

Parts List:

- | | |
|--------------------------------------|--------------------------------------|
| 1 - Big Tex Grille Guard Ring | 1 - Driver Front Bracket #77644-5 |
| 1 - Driver Side Upright | 1 - Passenger Front Bracket #77644-6 |
| 1 - Passenger Side Upright | 4 - 1/2" x 2" HH Bolts |
| 1 - Driver Rear Brace #46644-11 | 6 - 1/2" x 1 1/2" HH Bolts |
| 1 - Passenger Rear Brace #46644-12 | 10 - 1/2" Hex Nuts |
| 1 - Driver Bumper Brace #46644-9 | 10 - 1/2" Lock Washers |
| 1 - Passenger Bumper Brace #46644-10 | 20 - 1/2 Flat Washers |

1. Remove the contents from the box and check for missing pieces or damage. If parts are missing or damaged, contact the original place of purchase. Read the instructions completely before beginning. Two people are strongly recommended for this install.

View of Tow Hook Opening

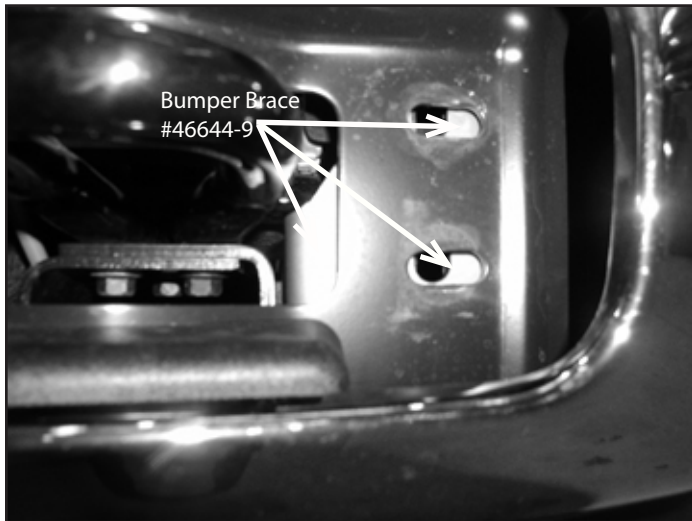

Diagram 2

View of Driver Bumper Brace #46644-9

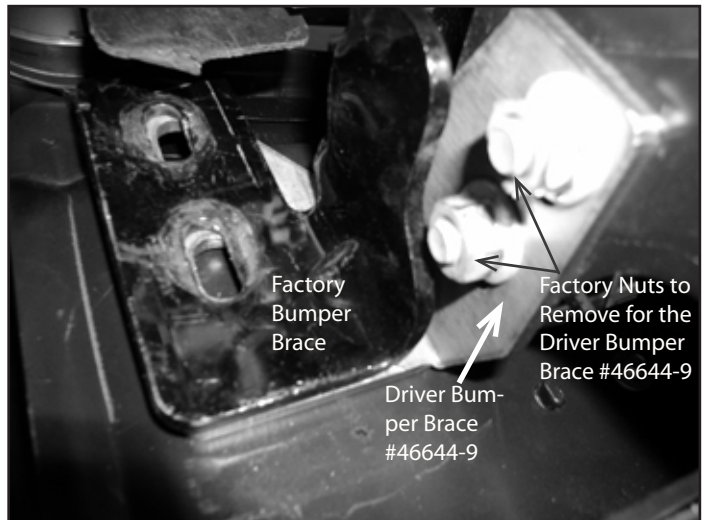

Diagram 3

2. As shown in **Diagram 2**, remove bumper bolts on both driver and passenger side. Set aside they will not be reused. Remove the factory nuts and bolts as shown in **Diagram 3**. Place the driver bumper brace #46644-9 between the bumper and the factory brace. As shown in **Diagram 3**, place Driver bumper brace #46644-9 up to the back of bumper and line up the 2 holes. Locate the two factory nuts in the frame that the driver bumper brace #46644-9 will attach to and replace the factory nuts, as shown in **Diagram 3**. Repeat above procedure for the passenger bumper brace #46644-10.

3. Install the passenger rear brace #46644-12 as shown in **Diagram 4**. Remove the two factory screws from the bumper brace as shown in **Diagram 4**. Only remove one side at a time or bumper will fall. Place the passenger rear brace #46644-12 up to the bumper brace and replace the factory screws. Place (1) 1/2" x 2" HH bolt with (1) 1/2" flat washer through the front bracket #77644-5 and through the bumper aligning the holes with the passenger bumper brace #46644-10 and the passenger rear brace #46644-12 and the factory brace as shown in **Diagram 4**. The bumper will have to be raised to align all of the holes. Place a (1) 1/2" flat washer, (1) 1/2" lock washer and (1) 1/2" hex nut onto the 1/2" x 2" HH bolt. Repeat procedure for all the holes. After all brackets are installed raise the bumper and tighten all bolts.

4. **Attach the Grille Guard to the mounting brackets:** Using two people align the Grille Guard holes to the top brackets. Attach the Grille to brackets using (1) 1/2" x 1 1/2" HH bolts, (2) 1/2" flat washers, (1) 1/2" lock washers and (1) 1/2" hex nuts per hole in upright. Hand tighten all bolts at this time.

5. **Center the Grille Guard on the vehicle:** Center the Grille Guard on the vehicle. Tighten all bolts at this time insuring the Grille Guard remains centered on vehicle.

View of Passenger Rear Brace #46644-12

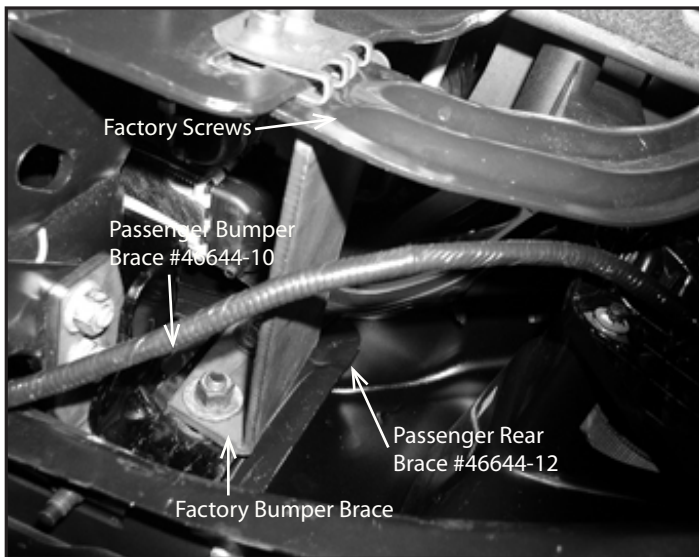

Diagram 4

View of Driver Front Bracket #77644-5

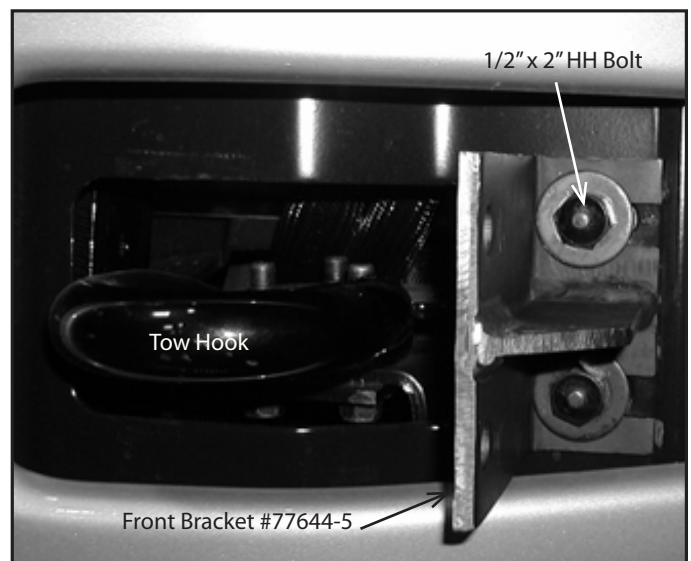

Diagram 5