

Big Tex Grille Guard

Installation Instructions

77720 & 77720B

Chevy Silverado 1500/1500HD/2500 (low profile) '03 - '05
 Chevy Avalanche 1500 w/o body hardware (low profile) '03 - '06

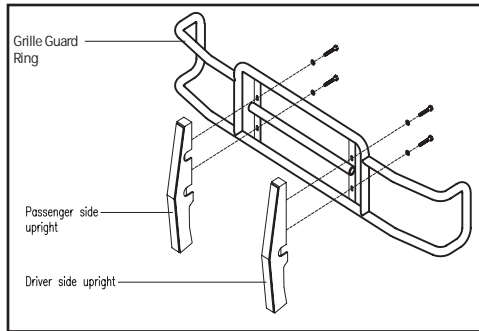

Diagram 1

Parts List:

1 - Grille Guard Ring #694	2 - M12 x 50mm HH Bolts
1 - Driver Side Upright	8 - 1/2" x 1 1/2" HH Bolts
1 - Passenger Side Upright	8 - 1/2" Flat Washers
1 - Driver Bottom Bracket #726-7	
1 - Passenger Bottom Bracket #726-8	
2 - Top Brackets #720-5	
2 - HD Bottom Brackets #720-9	
2 - Threaded Plates #699-9	

1 Remove the contents from the box and check for missing pieces or damage. If parts are missing or damaged, contact the original place of purchase. Read the instructions completely before beginning. Two people are strongly recommended for this install.

2 **Assemble the Grille Guard Ring and Uprights:** See **Diagram 1**, assemble the Uprights to the Grille Guard Ring. Each upright will get (2) - 1/2" x 1 1/4" hex head bolts and (2) - 1/2" flat washers that will go through the vertical plate on Grille Guard ring into upright. Hand tighten all bolts at this time.

3 **Remove the Factory Radiator Cover and Factory Grille:** Open the hood on the truck. Using **Diagram 2**, locate the factory radiator cover. To remove the pop rivets, use a flat head screwdriver to pull up on the middle of the pop rivets. To remove the bottom part of pop rivet, place the screwdriver under the bottom and push up. Repeat this procedure to remove all pop rivets. To remove the factory grille, place your hand behind grille and push out until the grille can be removed. Place the factory radiator cover, pop rivets and factory grille to the side to be re-installed later.

View of Factory Grille Removal

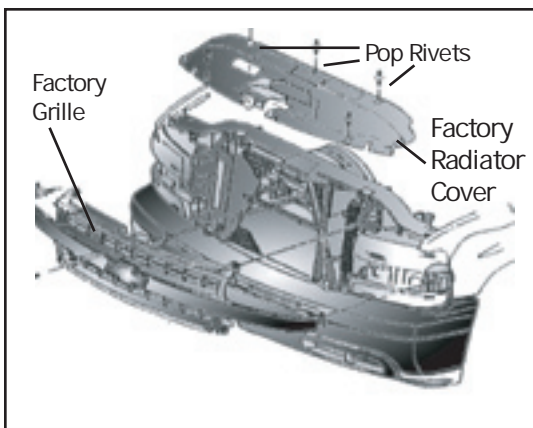

Diagram 2

Driver Side Top View of Top Bracket #720-5

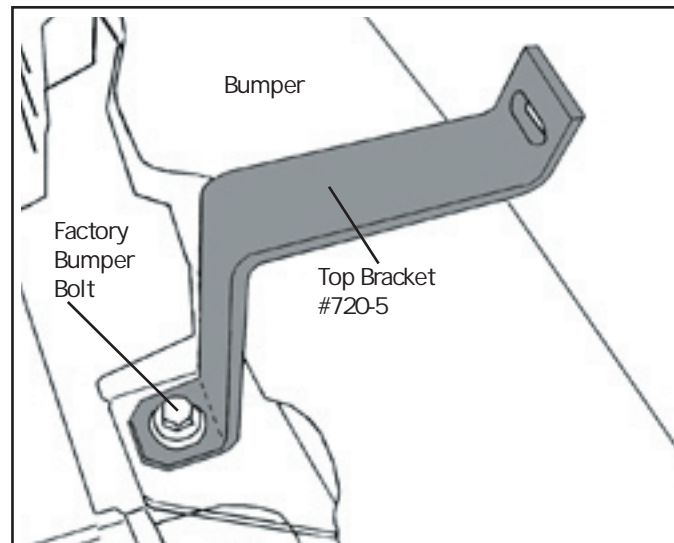

Diagram 3

4 **Install the Top Bracket #720-5 Driver and Passenger:** Locate the Top Bracket #720-5 for installation at this time.

A. Remove the factory bumper bolt as shown in **Diagram 3**. Place the Top Bracket #720-5 over the opening. Replace the factory bumper bolt through the top bracket and into the bolt hole opening. Hand tighten this bolt at this time.

B. Repeat step "A" above on the passenger side to install the Passenger Top Bracket #720-5.

C. Measure from middle of driver side bracket to middle of passenger side bracket and make sure it measures 32". Make sure brackets are square with bumper and tighten both bumper bolts.

**Front View of Driver Bottom Bracket
 #726-7 Attached to Upright**

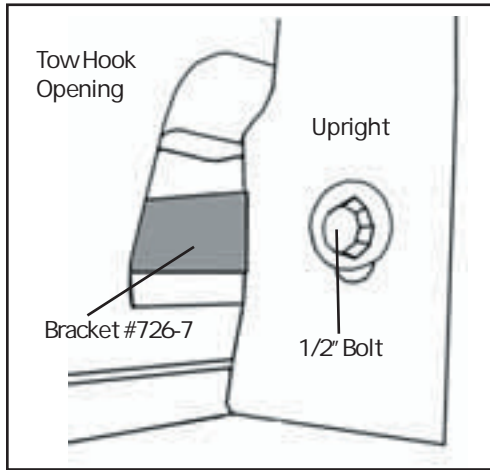

Diagram 4

**Front View of Driver Bottom Bracket
 #726-7 Attached to Upright**

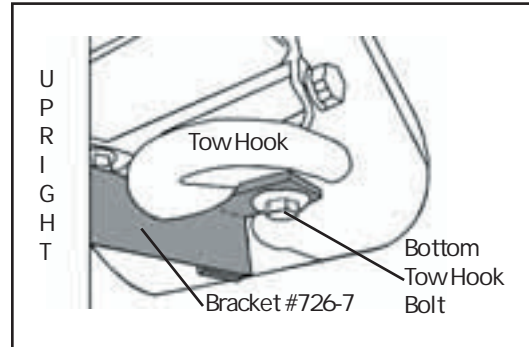

Diagram 5

**TowHook Opening Cover
 Driver Side**

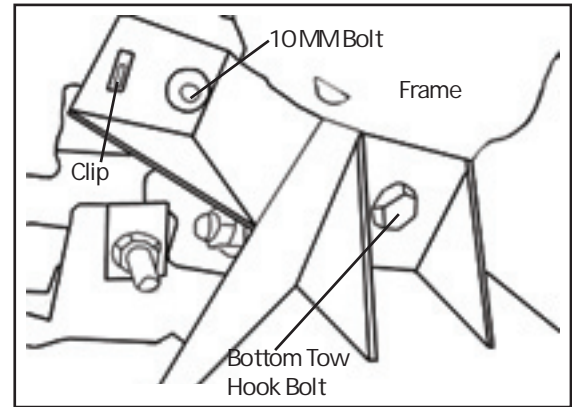

Diagram 6

5. Removal of TowHook Opening Cover: Remove the tow hook opening cover located behind the bumper. Remove the two 10mm bolts located on either side of the frame. Unclip the cover as shown in **Diagram 6**. Remove the cover by pulling it away from the frame. Some cutting will be necessary to put tow hook opening cover back on to frame.

6. For 1500 vehicles Install the Bottom Brackets #726-7: Locate the Bottom Brackets #726-7 for installation at this time.

A. Vehicles with towhooks: If the vehicle is equipped with tow hooks, locate the bottom bolt on tow hook. Loosen the bottom bolt and remove. Place flat end of Bottom Brackets #726-7 up to bottom bolt opening and replace the factory bolt with (1) M12 x 50mm hex head bolt. Hand tighten all bolts at this time.

B. Vehicles without towhooks: If the vehicle is not equipped with tow hooks, the plastic spoiler must be cut out for the bottom bracket to pass through. Align the bottom bracket with the inside hole on the frame and place bottom bracket against the plastic spoiler and mark the area to be cut. Carefully cut a slot for the bottom bracket to pass through the spoiler to the Grille Guard. Use threaded plate #699-9 to take place of tow hook. Place bracket #699-9 inside the frame and line up the threaded hole in the bracket #699-9 with the inside hole of frame. Place bottom bracket up to frame use a (1) 1/2" x 1 1/4" hex head bolt and attach bottom bracket to threaded plate. Hand tighten all bolts at this time.

