

Big Tex Grille Guard

Installation Instructions

77724 & 77724B

Chevy Silverado/Classic 2500HD/3500 (low profile) '03 - '07

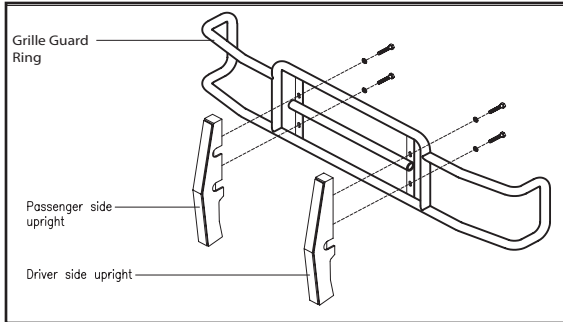

Diagram 1

Parts List:

1 - Grille Guard Ring	2 - M12 x 50mm HH Bolt
1 - Driver Side Upright	2 - Threaded Plates #699-9
1 - Passenger Side Upright	8 - 1/2" x 1 1/4" HH Bolts
2 - Top Brackets #724-5	10 - 1/2" Flat Washers
2 - Bottom Brackets #724-7	

Note: If your vehicle is not equipped with tow hooks, contact manufacturer for additional hardware.

1. Remove the contents from the box and check for missing pieces or damage. If parts are missing or damaged, contact the original place of purchase. Read the instructions completely before beginning. Two people are strongly recommended for this install.

2. **Assemble the Grille Guard Ring and Uprights:** See **Diagram 1**, assemble the Uprights to the Grille Guard Ring. Each upright will get (2) - 1/2" x 1 1/4" hex head bolts and (2) - 1/2" flat washers that will go through the vertical plate on Grille Guard ring into upright. Hand tighten all bolts at this time.

3. **Remove the Factory Radiator Cover and Factory Grille:** Open the hood on the truck. Using **Diagram 2**, locate the factory radiator cover. To remove the pop rivets, use a flat head screwdriver to pull up on the middle of the pop rivets. To remove the bottom part of pop rivet, place the screwdriver under the bottom and push up. Repeat this procedure to remove all pop rivets. To remove the factory grille, place your hand behind grille and push out until the grille can be removed. Place the factory radiator cover, pop rivets and factory grille to the side to be re-installed later.

View of Factory Grille Removal

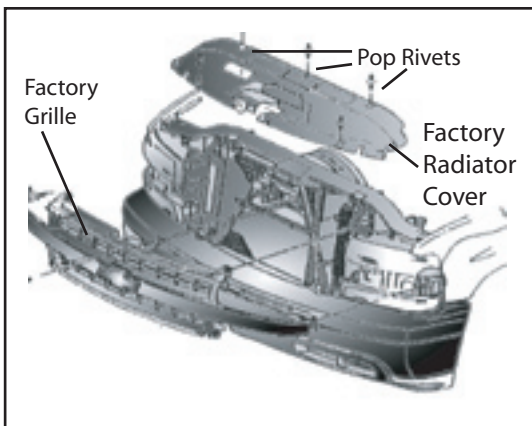

Diagram 2

Driver Side Top View of Top Bracket #724-5

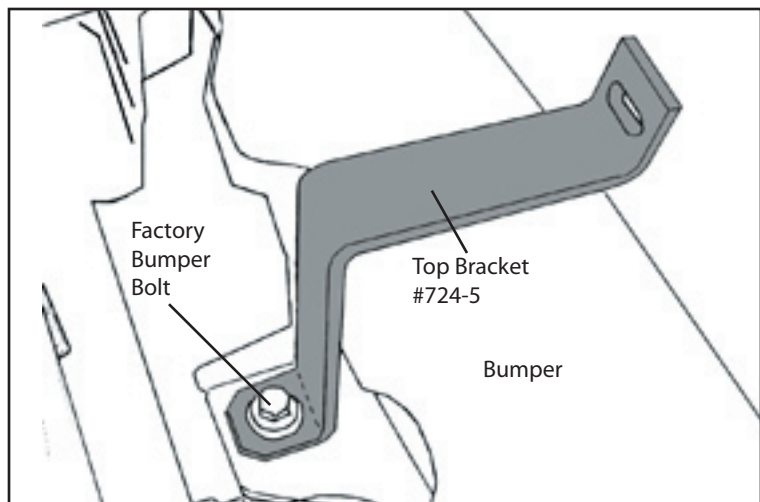

Diagram 3

4. **Install the Top Bracket #724-5 Driver and Passenger:** Locate the Top Bracket #724-5 for installation at this time.

A. Remove the factory bumper bolt as shown in **Diagram 3**. Place the Top Bracket #724-5 over the opening. Replace the factory bumper bolt through the top bracket #724-5 and into the bolt hole opening. Hand tighten this bolt at this time.

B. Repeat step "A" above on the passenger side to install the Passenger Top Bracket #724-5.

C. Measure from middle of driver side bracket to middle of passenger side bracket and make sure it measures 32". Make sure brackets are square with bumper and tighten both bumper bolts.

Front View of Driver Bottom Bracket #724-7

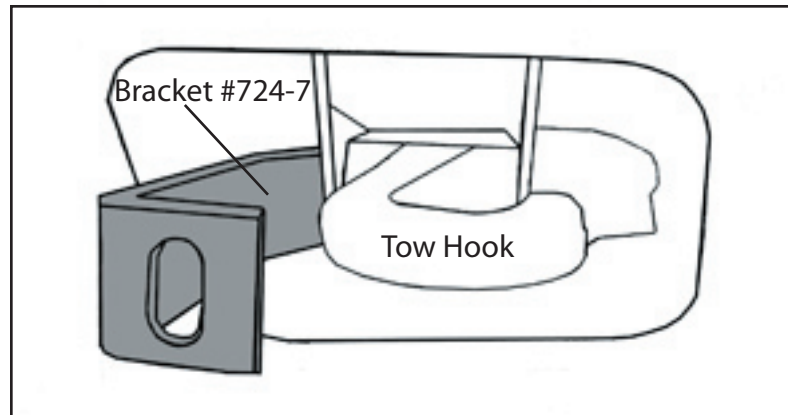

Diagram 4

5. **Install the Bottom Brackets #724-7:** Locate the Bottom Brackets #724-7 for installation at this time.

A. **Vehicles with tow hooks:** If the vehicle is equipped with tow hooks, locate the inside bolt on tow hook. Loosen the inside bolt and remove. Place flat end of Bottom Brackets #724-7 up to inside bolt opening and replace the factory bolt with (1) M12 x 50mm hex head bolt. Hand tighten all bolts at this time.

B. **Vehicles without tow hooks:** If your vehicle is not equipped with tow hooks, contact manufacturer for additional hardware.

6. **Re-install Factory Grille and Factory Radiator Cover:** Re-install Factory Grille and Factory Radiator Cover. Align Factory grille with holes in vehicle, gently push Factory Grille until it clicks closed. Take radiator cover place over holes in vehicle. Replace pop rivets into vehicle.

7. **Attach the Grille Guard to the mounting brackets:** Using two people align the Grille Guard holes to the top brackets. Attach the Grille to the top brackets using (1) 1/2" x 2" hex head bolts, (1) 1/2" flat washers per hole in upright. Hand tighten all bolts at this time.

8. **Center the Grille Guard on the vehicle:** Center the Grille Guard on the vehicle. Tighten all bolts at this time insuring the Grille Guard remains centered on vehicle.