

Big Tex Grille Guard Installation Instructions

77728 & 77728B

GMC Sierra/Classic 1500/1500HD/2500'03-'07

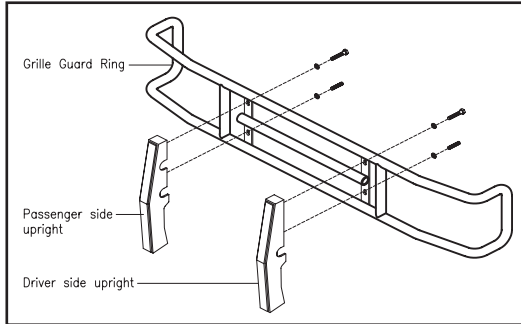

Diagram 1

Parts List:

1 - Grille Guard Ring #699	2 - M12 x 50mm HH Bolts
1 - Driver Side Upright	2 - 1/2" x 1" HH Bolts
1 - Passenger Side Upright	4 - 1/2" x 3" All-Thread Studs
2 - Bottom Bracket #724-7	6 - 1/2" x 1 1/2" HH Bolts
2 - Top Brackets #728-5	8 - 1/2" Hex Nuts
2 - Frame Brackets #728-9	14 - 1/2" Flat Washers
2 - Threaded Plates #699-9	

1. Remove the contents from the box and check for missing pieces or damage. If parts are missing or damaged, contact the original place of purchase. Read the instructions completely before beginning. Two people are strongly recommended for this install.

2. **Assemble the Grille Guard Ring and Uprights:** See **Diagram 1**, assemble the Uprights to the Grille Guard Ring. Each upright will get (2) - 1/2" x 1 1/4" hex head bolts and (2) - 1/2" flat washers that will go through the vertical plate on Grille Guard ring into upright. Hand tighten all bolts at this time.

3. **Remove the Factory Radiator Cover and Factory Grille:** Open the hood on the truck. Using **Diagram 2**, locate the factory radiator cover. To remove the pop rivets, use a flat head screwdriver to pull up on the middle of the pop rivets. To remove the bottom part of pop rivet, place the screwdriver under the bottom and push up. Repeat this procedure to remove all pop rivets. To remove the factory grille, place your hand behind grille and push out until the grille can be removed. Place the factory radiator cover, pop rivets and factory grille to the side to be re-installed later.

View of Factory Grille Removal

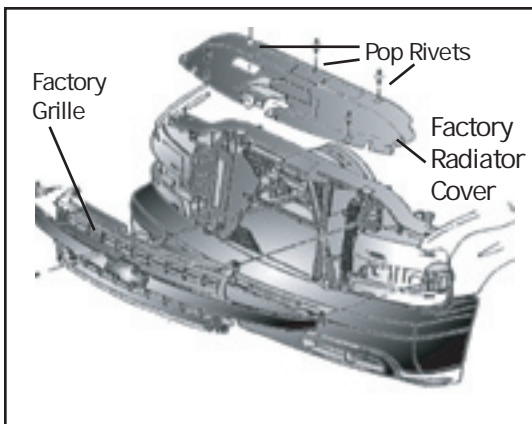

Diagram 2

Driver Side Top View of Top Bracket #728-5

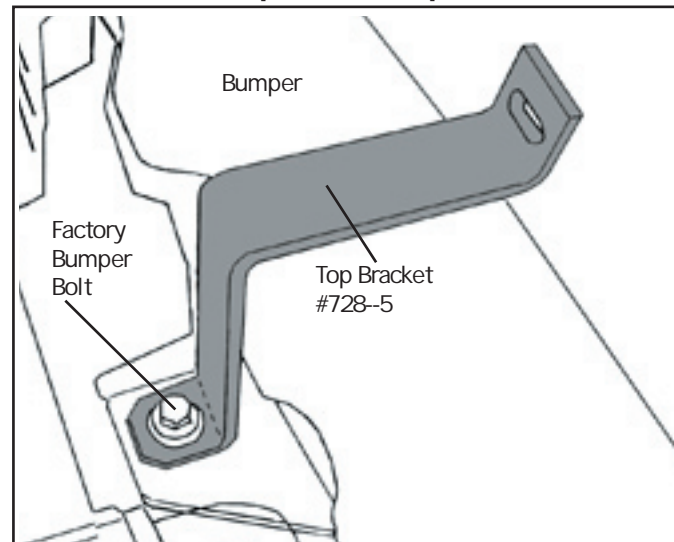

Diagram 3

4. **Install the Top Bracket #728-5 Driver and Passenger:** Locate the Top Bracket #728-5 for installation at this time.

A. Remove the factory bumper bolt as shown in **Diagram 3**. Place the Top Bracket #728-5 over the opening. Replace the factory bumper bolt through the top bracket and into the bolt hole opening. Hand tighten this bolt at this time.

B. Repeat step "A" above on the passenger side to install the Passenger Top Bracket #728-5.

C. Measure from middle of driver side bracket to middle of passenger side bracket and make sure it measures 32". Make sure brackets are square with bumper and tighten both bumper bolts.

View of Frame with Bracket Placement

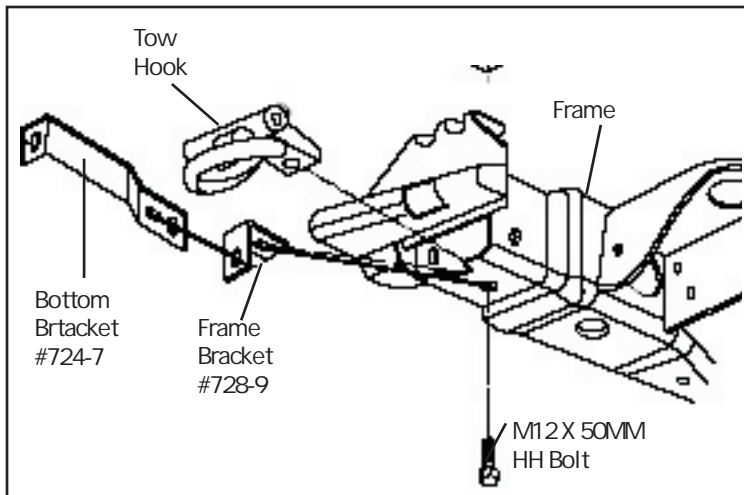

Diagram 4

View of 1500HD Frame with Bracket Placement

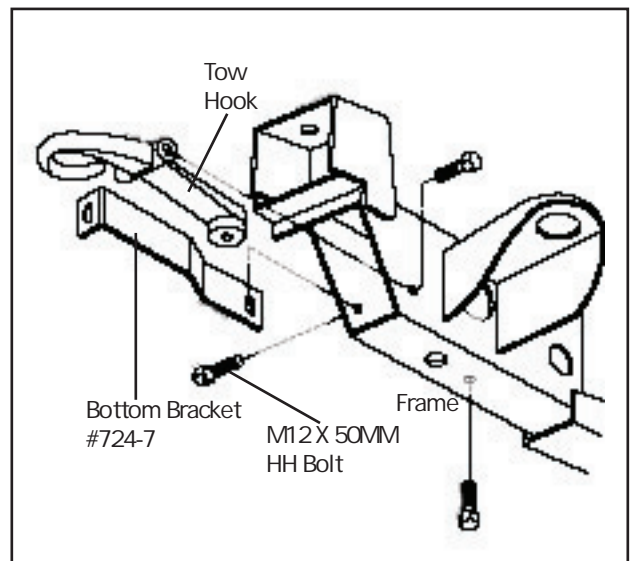

Diagram 5

5. **For 1500 vehicles Install the Bottom Brackets #724-7 and Frame Bracket #728-9:** Using **Diagram 4**, Locate the bottom brackets #724-7 and frame bracket #728-9 for installation at this time.

A. Vehicles with towhooks: If the vehicle is equipped with towhooks, locate the bottom bolt on towhook. Loosen the bottom bolt and remove. Place flat end of the frame brackets #728-9 up to bottom bolt opening and replace the factory bolt with (1) M12 x 50mm hex head bolt in kit as shown in **Diagram 4** and **Diagram 5**. Frame bracket #728-9 will come to the inside of the frame and point to the ground. Place bottom bracket #724-7 up to frame bracket #728-9. Using the second hole in bottom bracket #724-7, place (1) 1/2" x 1" HH Bolt through opening and (1) 1/2" flat washer, (1) 1/2" hex nut onto bolt and hand tighten. Hand tighten all bolts at this time. Repeat above procedure for passenger bottom bracket #724-7.

B. Vehicles without towhooks: If the vehicle is not equipped with towhooks, the plastic spoiler must be cut out for the bottom bracket to pass through. Align the bottom bracket with the inside hole on the frame and place bottom bracket against the plastic spoiler and mark the area to be cut. Carefully cut a slot for the bottom bracket to pass through the spoiler to the Grille Guard. Use threaded plate #699-9 to take place of towhook. Place bracket #699-9 to the inside of the frame and line up the threaded hole in the bracket #699-9 with the bottom hole of frame. Place frame bracket #728-9 up to frame use (1) 1/2" x 1 1/4" hex head bolt and attach frame bracket #728-9 to threaded plate #699-9. Frame bracket #728-9 will come to the inside of the frame and point to the ground. Place bottom bracket #724-7 up to frame bracket #728-9. Using the second hole in bottom bracket #724-7 place (1) 1/2" x 1" HH Bolt through opening and (1) 1/2" flat washer, (1) 1/2" hex nut onto bolt and hand tighten. Hand tighten all bolts at this time. Repeat above procedure for passenger bottom bracket #724-7.

6. **For 1500HD/2500 nonHD Install the Bottom Brackets #724-7:** Using **Diagram 5**, locate the bottom brackets #724-7 for installation at this time.

A. Vehicles with towhooks: If the vehicle is equipped with towhooks, locate the inside bolt on towhook. Loosen the inside bolt and remove. Place flat end of driver bottom brackets #724-7 up to inside bolt opening and replace the factory bolt with (1) M12 x 50mm hex head bolt as shown in **Diagram 5**. Hand tighten all bolts at this time. Repeat above procedure to install passenger bottom bracket #724-7.

B. Vehicles without towhooks: If the vehicle is not equipped with towhooks, the plastic spoiler must be cut out for the bottom bracket to pass through. Align the bottom bracket with the inside hole on the frame and place bottom bracket against the plastic spoiler and mark the area to be cut. Carefully cut a slot for the driver bottom bracket #724-7 to pass through the spoiler to the Grille Guard. Place bracket #699-9 to the inside of the frame and line up the threaded hole in bracket #699-9 with the inside hole of frame. Place driver bottom bracket #724-7 up to frame use (1) 1/2" x 1 1/4" hex head bolt and attach bottom bracket to threaded plate. Hand tighten all bolts at this time. Repeat above procedure to install passenger bottom bracket #724-7.

