

Big Tex Grille Guard
 Installation Instruction
77735 & 77735B
 Chevy Silverado 1500 (New Body) '07-'08

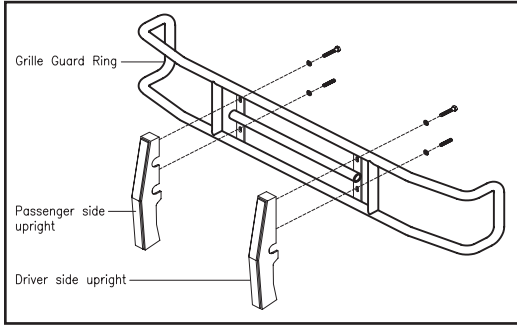

Diagram 1

Parts List:

1 - Grille Guard Ring	2 - M10 x 40mm HH Bolt
1 - Driver Side Upright	2 - M10 Flat Washers
1 - Passenger Side Upright	2 - Spacers
1 - Driver Top Brackets #735-5	10 - 1/2" x 1 1/2" HH Bolt
1 - Passenger Top Brackets #735-6	10 - 1/2" Flat Washers
2 - Bottom Brackets #735-7	

Note: If your vehicle is not equipped with tow hooks, please call (800) 527-4345 for additional parts.

1. Remove the contents from the box and check for missing pieces or damage. If parts are missing or damaged, contact the original place of purchase. Read the instructions completely before beginning. Two people are strongly recommended for this install.

2. **Assemble the Grille Guard Ring and Uprights:** Using **Diagram 1**, assemble the Uprights to the Grille Guard Ring using (4) 1/2" x 1 1/2" hex head bolts and (4) 1/2" washers. Hand tighten all bolts at this time.

3. **Remove the Factory Radiator Cover and Factory Grille:** Open the hood on the truck. Using **Diagram 2**, locate the factory radiator cover. To remove the pop rivets, use a flat head screwdriver to pull up on the middle of the pop rivets. To remove the bottom part of pop rivet, place the screwdriver under the bottom and push up. Repeat this procedure to remove all pop rivets. To remove the factory grille, loosen and remove the 4-10mm bolts. Take a pair of needle nose pliers and push down on the middle of each clip to remove factory grille. Place the factory radiator cover, pop rivets and factory grille to the side to be re-installed later.

View of Factory Grille and Radiator Cover

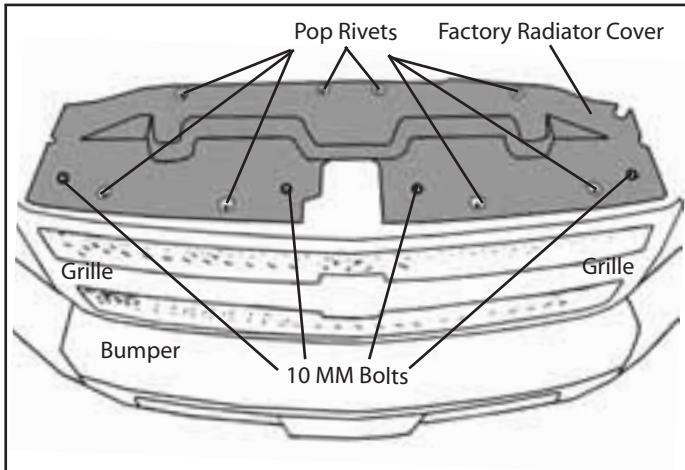

Diagram 2

Side View of Driver Top Bracket #735-5

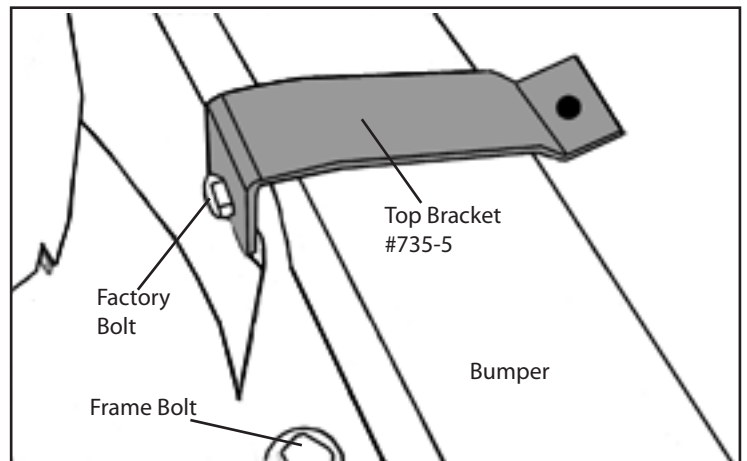

Diagram 3

4. **Install the Top Bracket #735-5 Driver and #735-6 Passenger:** Locate the Top Bracket #735-5 & 735-6 for installation at this time.

A. **Install Driver Top Bracket #735-5:** Using **Diagram 3** locate the factory bolt closest to headlight and remove. Replace the factory bolt with (1) M10 x 40mm HH Bolt provided in bolt kit. Place a spacer provided in kit, between the bracket and the bumper. Place the 10mm bolt through the bracket, spacer and into threads in bumper. Hand Tighten at this time

B. Repeat above procedure to install Passenger Top Bracket #735-6.

Front View of Bottom Bracket #735-7 (Driver Side)

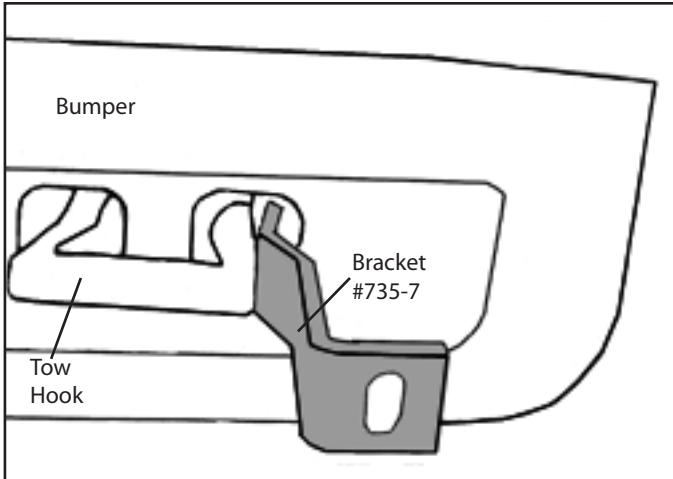

Diagram 4

View Behind Bumper of Bottom Bracket #735-7 (Driver Side)

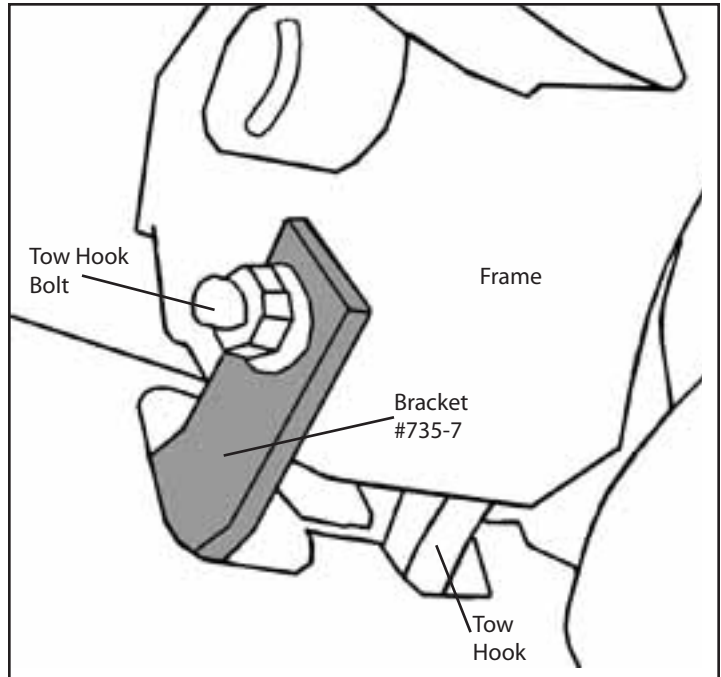

Diagram 5

5. **Install the Bottom Brackets #735-7:** Locate the Bottom Brackets #735-7 for installation at this time.

A. **Vehicles with tow hooks:** Using Diagram 5, attach Driver Bottom Bracket #735-7. If the vehicle is equipped with tow hooks, locate the bolt on tow hook. Loosen the bolt and remove Nut. Place flat end of Bottom Brackets #735-7 through tow the hook opening on the outside up against bolt and replace factory nut. Bracket #735-7 should be on the outside of tow hook, refer to **Diagram 4**. Repeat the procedure for the Passenger Side Bracket #735-7. The tow hook bolt will have to be removed. Place the bracket onto bolt and then replace the tow hook bolt. Hand tighten all bolts at this time.

B. **Vehicles without tow hooks, please call (800) 527-4345 for additional parts. When you receive the parts, use the following procedure to install grille guard:** If the vehicle is not equipped with tow hooks, the plastic spoiler must be cut out for the bottom bracket to pass through. Align the bottom bracket with the inside hole on the frame and place bottom bracket against the plastic spoiler and mark the area to be cut. Carefully cut a slot for the bottom bracket to pass through the spoiler to the Grille Guard. Use threaded plate #699-9 to take place of tow hook. Place bracket #699-9 inside the frame and line up the threaded hole in bracket #699-9 with the inside hole of frame. Place bottom bracket #735-7 up to frame use (1) 1/2" x 1 1/4" hex head bolt and attach bottom bracket #735-7 to threaded plate. Hand tighten all bolts at this time.

6. **Re-install Factory Grille and Factory Radiator Cover:** Re-install Factory Grille and Factory Radiator Cover. Align Factory grille with holes in vehicle and gently push Factory Grille until it clicks closed. Take radiator cover place over holes in vehicle. Replace pop rivets into vehicle.

7. **Attach the Grille Guard to the mounting brackets:** Using two people align the Grille Guard holes to the top brackets. Attach the Grille to the top brackets using (1) 1/2" x 2" hex head bolts, (1) 1/2" flat washers, per hole in upright. Hand tighten all bolts at this time.

8. **Center the Grille Guard on the vehicle:** Center the Grille Guard on the vehicle. Tighten all bolts at this time insuring the Grille Guard remains centered on vehicle.