

Big Tex Grille Guard

Installation Instructions

77656 / 77656B

Ford F-150 2018

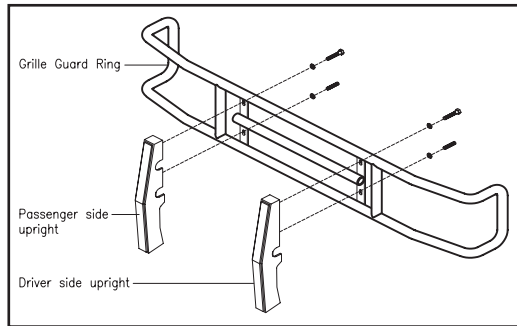

Diagram 1

Parts List:

1-Grille Guard Ring	6 - 1/2"-13 Hex nuts
1-Driver Side Upright	14 - 1/2" x 1 1/2" Bolts
1-Passenger Side Upright	20 - 1/2" Flat Washers
1-Driver Side Upper Bkt #46656-5	14 - 1/2" Lock Washers
1-Pass. Side Lower Bkt #46656-6	
1-Driver Side Upper Bkt #46650-7	*May include extra hardware.
1-Pass. Side Lower Bkt #46650-8	
2-Nut Plates #46639-9	

Note: Completely read instructions before beginning installation!

1. Remove the contents from the box and check for missing pieces or damage. If parts are missing or damaged, contact the original place of purchase.
2. If vehicle comes equipped with factory tow hooks. The factory tow hooks will have to be removed. The tow hooks will not be reused. The brackets are equipped with holes to be used as the tow hooks.
3. Remove plastic finish panel in the center of the factory bumper by squeezing clips from behind bumper, then pushing outward. Unplug fog lamps, if equipped, then remove rear bumper nuts. In the front, remove the two bumper nuts on each side and remove bumper. (**see diagram 2**)
4. Reuse the factory nut plate in the frame if equipped (or the 46639-9 nutplate if no tow hooks were originally installed) and line up the 2 holes on the bottom of the frame with the holes on the nut plate. It is recommended to use tape to hold the nut plate in place because access will be limited later. Do not install lower brackets at this time. Reinstall factory upper bolt plates and hang the upper brackets #46656-5 (driver's) #46656-6 (passenger) on the bolt plate against the frame. (**see diagram-3**) Reinstall the front bumper, sandwiching the upper bracket between the frame and the bumper. Reinstall the factory bumper nuts but do not tighten at this time.
5. Install the lower brackets #46650-8 and #46650-9 to the frame where the tow hooks were removed. Thread the factory tow hook bolts (or the new hardware) through the lower brackets into the previously installed nut plate. (Hint: install the rear bolts first) (**see diagram-4 & 5**)
6. At this time, assemble the (2) uprights onto the Grille Guard ring using (4) 1/2"-13x1 1/2" bolts with (4) 1/2" flat washers and (4) 1/2" lock washers.
7. Place (1) 1/2" flat washer on to each of the (6) 1/2" x 1 1/2" bolts. Using the (6) bolts with washers attach the uprights to the brackets with (6) 1/2" flat washers, (6) 1/2" lock washers and (6) 1/2"-13 hex nuts. Hand tighten all bolts at this time.
8. While centering the grille guard on the vehicle, tighten the lower bracket to frame bolts. Then tighten all six factory bumper bolts and plug in fog lamps. There will not be any up and down adjustment in the bumper.
9. Remove the bolts connecting the upper bracket to the grille guard and one set of lower bracket bolts. Carefully tilt the grille guard forward and reinstall the plastic filler in the center of the bumper. Reinstall the bracket bolts and tighten all bolts.

Big Tex Grille Guard

Installation Instructions

77656 / 77656B

Ford F-150 2018

View of Bumper on Vehicle Without Plastic filler



Diagram 2

Driver Side upper bracket # 46656-5

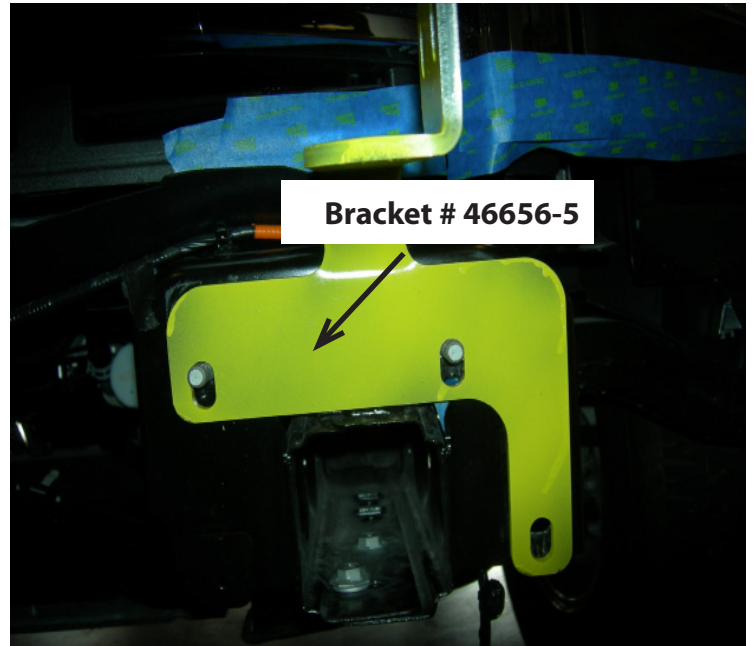

Diagram 3

Underside View of Driver Bracket #46650-7



Diagram 4

View of Driver Side Bracket #46650-7 with bumper



Diagram 5