

420 N. Grove, Richardson, TX 75081
 Tele: (800) 527 - 4345 Fax: (800) 442 - 5263
 Web site: www.goindustries.com
 E-mail: gosupport@goindustries.com

Big Tex Grille Guard

Installation Instructions

77660 - 77660B

Dodge Ram '02 - '05 1500

Dodge Ram '03 - '05 2500/3500 w/o tow hooks

77661 - 77661B

Dodge Ram '03 - '05 2500/3500 with tow hooks

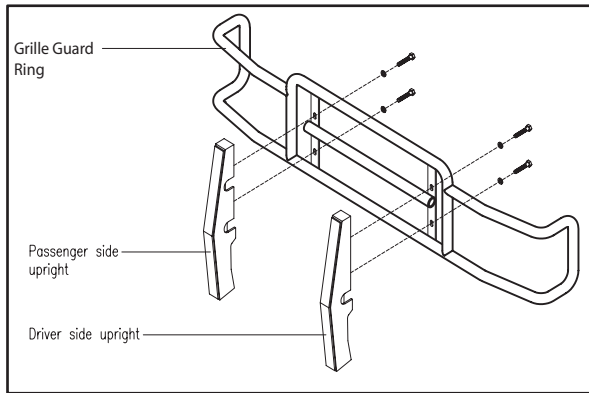

Diagram 1

Parts List

1 - Grille Guard Ring	2 - 1/2" x 5 1/2" Bolts
1 - Driver Side Upright	6 - 1/2" x 1 1/4" Bolts
1 - Passenger Side Upright	2 - 1/2" x 2 3/4" Studs
1 - Driver Top Bracket #615	12 - 1/2" Flat Washers
1 - Pass. Top Bracket #616	2 - 1/2" Lock Washers
2 - Bottom Brackets #660-7	4 - 1/2" Hex Nuts
2 - 1 hole Spacers	

* May include extra hardware

Note: Will not fit the Ram Sport or Rams with plastic bumper covers

Note: Completely read instructions before beginning installation!

1. Remove the contents from the box and check for missing pieces or damage. If parts are missing or damaged, contact the original place of purchase. Two people are strongly recommended for this install.
2. Using **Diagram 1**, assemble the uprights to the Grille Guard Ring. Each upright will get (2) - 1/2" x 1 1/4" hex head bolts and (2) - 1/2" flat washers that will go through the vertical plate on Grille Guard ring into upright. Hand tighten all bolts at this time.
3. Open the hood on the truck, using **Diagram 2**, locate the bumper bolt on each side of the vehicle. Remove the factory nut from the bolt. Locate the Driver and Passenger Top Brackets, #615 and #616. Place Driver Top Bracket #615 onto the bumper bolt (Refer to **Diagram 3**). The end of the Driver Top Bracket #615 with the 90 degree bend will go onto the bumper bolt. Replace the factory nut and hand tighten at this time. Repeat on the passenger side to install the passenger Top Bracket #616.

View Behind Bumper (Driver Side)

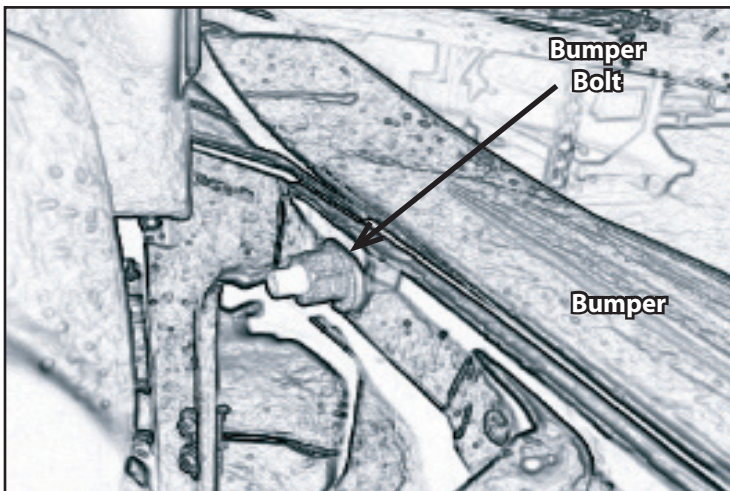

Diagram 2

Driver Top Bracket #615 Installed

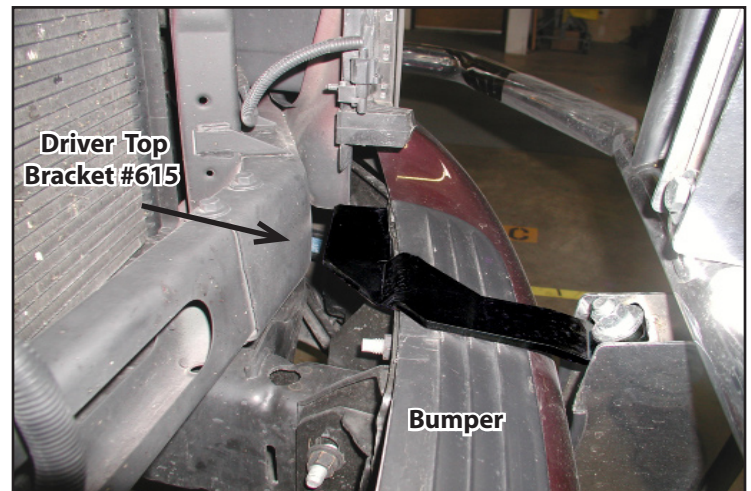

Diagram 3

Big Tex Grille Guard

Installation Instructions

77660 - 77660B

Dodge Ram '02 - '05 1500

Dodge Ram '03 - '05 2500/3500 w/o tow hooks

77661 - 77661B

Dodge Ram '03 - '05 2500/3500 with tow hooks

4. Using **Diagram 4**, prepare the upright to attach the grille guard/upright assembly to the top brackets. Place a 1/2" x 2 3/4" all-thread stud into the welded plate (second from bottom) on the back of the driver side upright. The all-thread stud will pass through the bottom of the welded plate approximately 1/4". Place a 1/2" hex nut over the all-thread stud and screw the nut down to approximately 1/4" from the welded plate. Place a 1/2" flat washer onto the all-thread stud on top of the 1/2" hex nut. Repeat steps for the passenger side upright. Using two people, hold the grille guard/upright assembly up to the top brackets on the vehicle. Place the all-thread studs on the uprights through the end of the driver and passenger top brackets. Place a 1/2" flat washer, 1/2" lock washer and 1/2" hex nut onto the all-thread stud. Hand tighten the nuts and bolts at this time.

5. Using **Diagram 5**, locate the bottom bumper bolt on the vehicle. Remove the factory nut from the bottom bumper bolt. Place the provided metal spacer from kit onto the factory bottom bumper bolt followed by the Bottom Bracket #660-7. Re-place the factory nut over the bottom bracket. Repeat the procedure for the opposite side.

6. **A 1/2" hole must be drilled into the black plastic down spoiler to allow the 1/2" X 5 1/2" hex head bolt to pass through to the upright; see Diagram 5.** To mark the location on the back of the black down spoiler for the 1/2" hole, place the 1/2" x 5 1/2" bolt through the hole in the bottom bracket and against the black plastic down spoiler. Make sure the bolt is level and mark the location of the bolt against the black plastic spoiler. Using a 1/2" drill bit, drill a 1/2" hole into the black plastic down spoiler. Place the 1/2" x 5 1/2" hex head bolt through the bottom bracket (#660-7), and through the 1/2" hole in the black plastic down spoiler. Start the bolt into the bottom welded plate on the upright. Repeat the procedure for the opposite side.

8. Tighten the 1/2" x 5 1/2" hex head bolt (located on the bottom brackets) until upright is touching vehicle's bumper. Adjust the top 1/2" stud (located on the top brackets) until grille guard/upright assembly is level on vehicle. Tighten all bolts at this time insuring Grille Guard remains centered on vehicle.

Caution:

Lower hood carefully, make sure there is clearance for the hood to close. Damage could occur if hood is closed onto Grille Guard. Note: Grill Guard can be adjusted for clearance by loosening top bracket and tightening bottom bracket bolt.

Assembly of Bolt Attachment

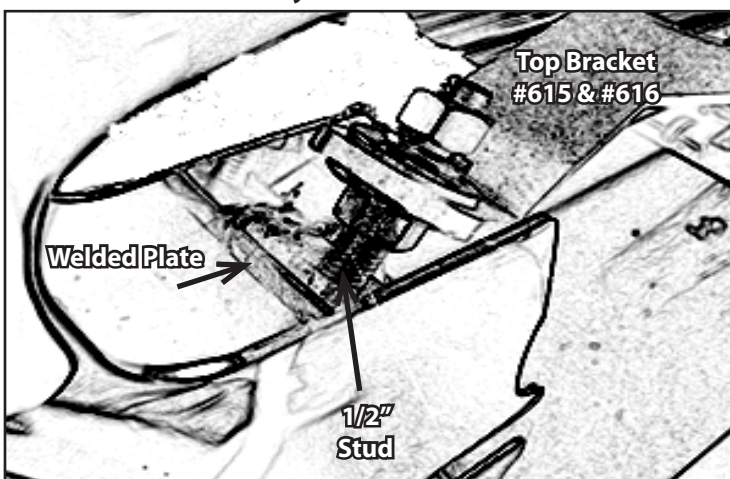

Diagram 4

Behind Bumper View of Bottom Bracket

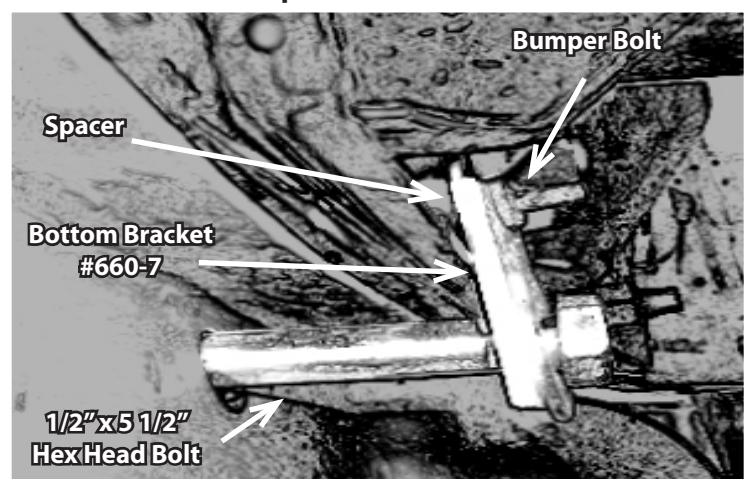

Diagram 5