

# Winch Carrier

## Installation Instructions

### 33601



**\*\*Does not include winch or grille guard**

**Diagram 1**

**Parts List:**

- |                                  |                                     |
|----------------------------------|-------------------------------------|
| 1 - Winch Carrier                | 4 - 1/4" x 3/4" Bolts               |
| 2 - License Plate Brackets       | 4 - 1/4" Nylon Lock Nuts            |
| 6 - 1/2" x 2 1/4" Carriage Bolts |                                     |
| 6 - 1/2" Lock Washers            |                                     |
| 6 - 1/2" Nuts                    | <b>*May include extra hardware.</b> |

**Note: Completely read instructions before beginning installation!**

1. Remove the contents from the box and check for missing pieces or damage. If parts are missing or damaged, contact the original place of purchase.
2. Using **Diagram 2** install the winch carrier between the uprights on grille guard. Use (6) 1/2" x 2 1/4" carriage bolts to install the winch carrier. Place (1) 1/2" lock washer, (1) 1/2" flat washer and (1) 1/2" nut onto each carriage bolt. Hand tighten at this time. After grille guard has been tightened then tighten all carriage bolts. On some model guards the bolts connecting the carrier to the uprights will also connect the brackets to the uprights.
3. If a front license plate is required in your state, attach the license plate brackets to the bottom of the winch carrier with the (2) 1/4 x 3/4" bolts, (2) 1/4" locking nuts as shown in **Diagram 3**.

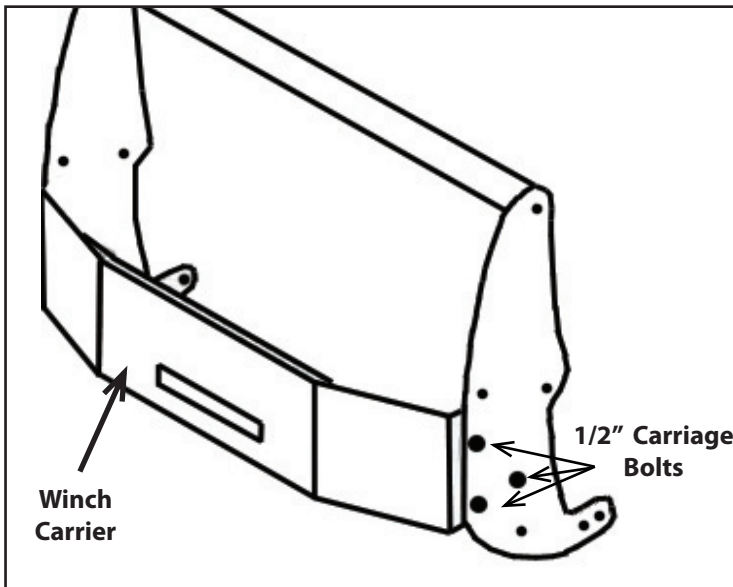

**Diagram 1**

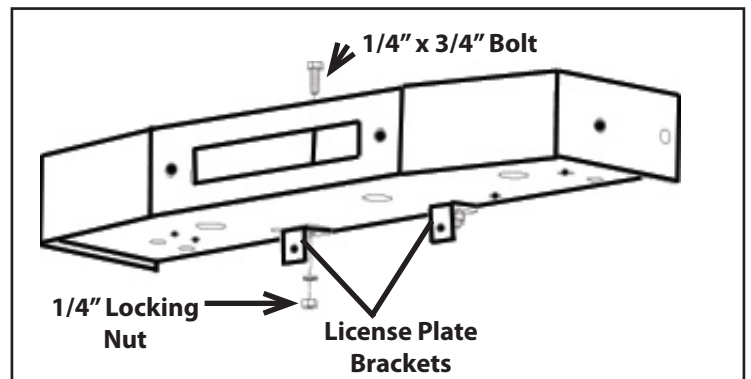

**Diagram 3**