

# Winch System Grille Guard

## Installation Instructions

### **33644 / 33644B**

Ford Super Duty '11-'16



**Diagram 1**

**Parts List:**

2 - Uprights	2 - 5/8" Lock Washers
2 - 2 1/2" x 32" Cross Tubes	2 - 5/8" Nuts
1 - Driver Upper Bracket #33642-5	8 - 1/2" x 1 1/2" Bolts
1 - Pass. Upper Bracket #33642-6	8 - 1/2" x 2" Bolts
1 - Driver Lower Bracket #33644-7	16 - 1/2" Nuts
1 - Pass. Lower Bracket #33644-8	16 - 1/2" Lock Washers
1 - Driver Bumper Support #33644-9	32 - 1/2" Flat Washers
1 - Pass. Bumper Support #33644-10	4 - 3/8" x 1 1/2" Buttonhead Bolts
2 - 5/8" x 1 3/4" Bolts	4 - Neoprene Washers
2 - 5/8" Flat Washers	

**\*May include extra hardware.**

**Note: Completely read instructions before beginning installation!**

1. Remove the contents from the box and check for missing or damaged parts. If parts are missing or damaged, contact the original place of purchase.
2. Remove the two bolts from the outside bumper support. Do this on both driver and passenger side. Bolts will be reused. Using **Diagram 2**, remove the 2 bumper bolts. Set bolts and nut plate aside it will be reused. Repeat this procedure for the passenger side. Unplug any fog or driving light harness, remove the bumper and set aside.
3. Using **Diagram 3**, remove the 3 bolts holding factory tow hook. Remove the tow hook assembly, set aside it will not be reused.

**Note: On Steps #4-5 Use supplied Zinc Hardware, on Steps # 5-6 use supplied Black hardware.**

4. Replace factory tow hook assembly with driver upper bracket #33642-5 and driver bumper support #33644-9 as shown in **Diagram 4**. The driver bumper support bracket #33644-9 needs to be placed on top of the mounting pad of bracket #33644-5. Use (3) 1/2" x 2" bolts in place of factory bolts. Place bolt through both brackets and into the frame. Place (2) 1/2" flat washer, (1) 1/2" lock washer and (1) 1/2" nut onto each bolt only hand tighten at this time. Repeat procedure for the passenger side using brackets #33642-6 and #33644-10.

**\*\*Brackets # 33644-9 and #33644-10 must be installed as illustrated in Diagram 4.\*\***

**\*\*The manufacturer is not responsible for damage to vehicle from brackets #33644-9 and #33644-10 installed incorrectly.\*\***

**Driver Side**

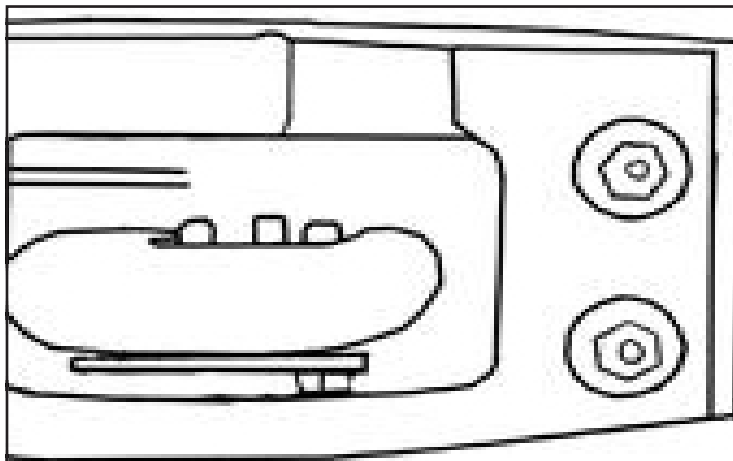

**Diagram 2**

**Driver Side underside of Factory Tow hook**

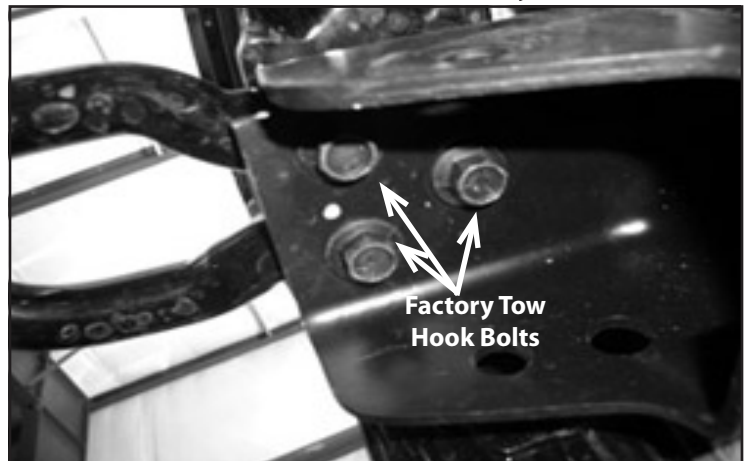

**Diagram 3**

420 N. Grove, Richardson, TX 75081  
 Tele: (800) 527 - 4345 Fax: (800) 442 - 5263  
 Web site: www.goindustries.com  
 E-mail: gosupport@goindustries.com

# Winch System Grille Guard

Installation Instructions

## 33644 / 33644B

Ford Super Duty '11-'16

5. If vehicle in equipped with anti-dive brackets, remove them and set aside at this time, shown in **Diagram 4**. Using **Diagram 5**, place the driver bottom bracket #33644-7 up to frame. Place (1) 1/2" x 1 1/2" bolt in the front hole through the frame, put on (2) 1/2" flat washer, 1/2" lock washer and a 1/2" nut each bolt. Hand tighten at this time. Place (1) 5/8" x 1 1/4" bolt through the second hole with (1) 5/8" flat washer, (1) 5/8" lock washer and (1) 5/8" nut. Hand tighten at this time. Repeat procedure for the passenger side bracket #33642-6.

6. To tighten all bolts on the brackets the following must be done. The uprights will have be assembled to tubes and mounted to the installed brackets. Assemble cross tubes to uprights using (1) 3/8" x 1 1/2" buttonhead bolt and plastic washer threaded into tube end. Using **Diagram 6**, place uprights with tubes up to the main bracket and bottom brackets. Place (4) 1/2" bolts through brackets into uprights and place (2) 1/2" flat washer and (1) 1/2" Lock Washer and (1) 1/2" nut onto bolt. Upper Brackets #33644-5 and 6 use (1) 1/2" x 2" bolt on front hole, use (2) 1/2" x 1 1/2" bolts in the six other bracket holes. Tighten all bolts on the main and bottom brackets. After all bolts are tightened unbolt the uprights and remove. For some applications the bottom spoiler will need to be trimmed before the bumper can be reinstalled..

7. Using **Diagram 7**, replace bumper. Bumper will need to rolled back to place on truck. Brackets will go through the tow hook opening and through or below the bottom plastic spoiler. Use the factory bolts to attach bumper to bumper bracket. Push bumper up when tightening all four factory bolts. Place uprights up to the main and bottom brackets as shown in **Diagram 7**, using (4) 1/2" bolts to attach upright to brackets. Hand tighten bolts. If a winch carrier is going to be installed, install at this time. Install the cross tubes after winch carrier has been installed. Tighten all bolts. If installing a Winch carrier refer to carrier instructions for installation.

**Driver Side Brackets Installed**

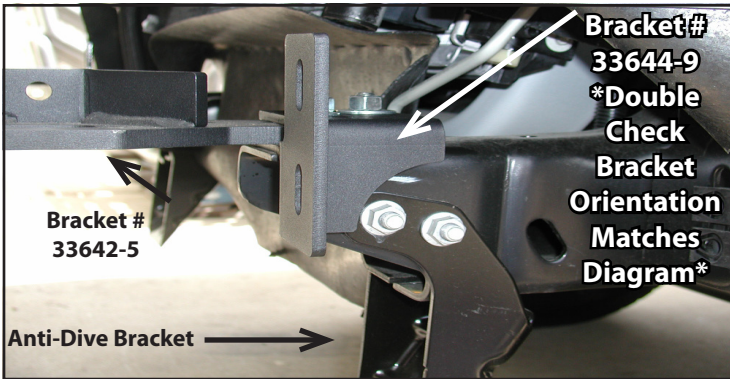

**Diagram 4**

**Driver Side Bracket # 33644-7**

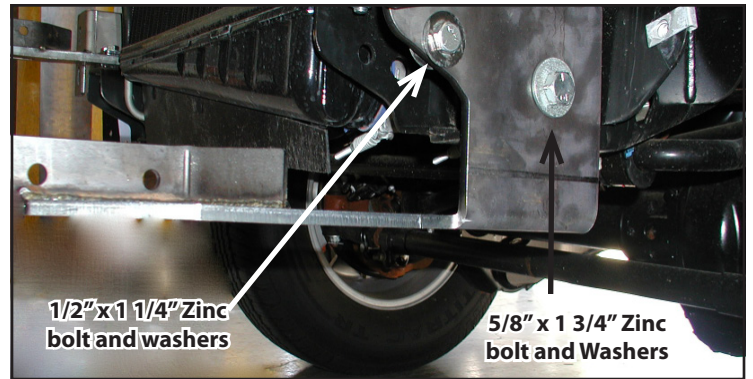

**Diagram 5**

**Driver Side Brackets Installed**

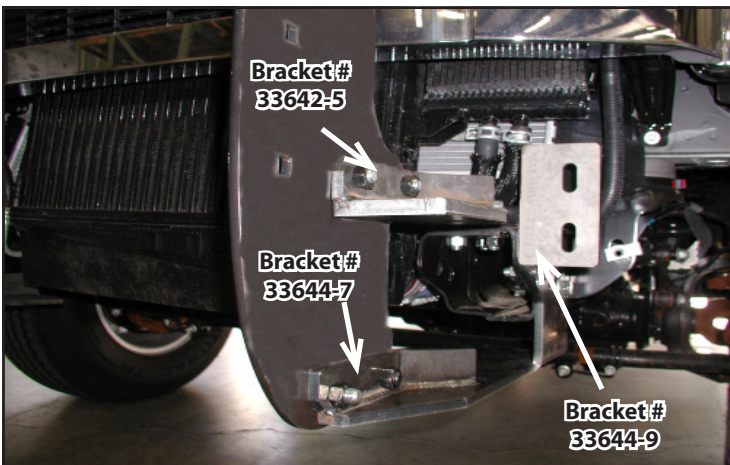

**Diagram 6**

**Driver Side With brackets and Bumper Reinstalled**

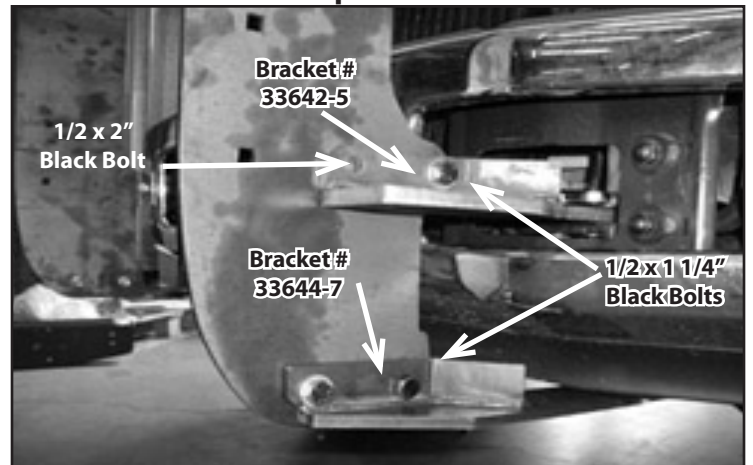

**Diagram 7**