

# Rancher Rugged Step

Installation Instructions

## 42362

Dodge Ram Mega Cab

1500 '06-'08

2500/3500 '06-'09

### **NOTE: Rancher Rugged Steps ship in three boxes.**

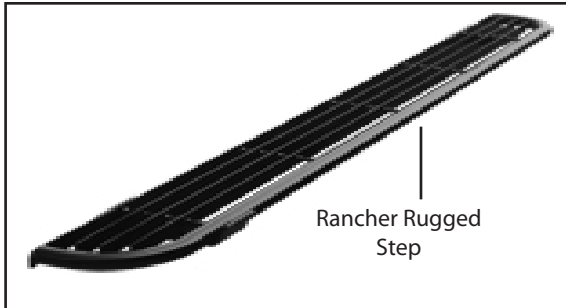

**Diagram 1**

**Parts List:**

2 - Rancher Rugged Step	1 - 1/2" x 4" Bolt
2 - Front Bracket #42360-5	6 - 1/2" x 1 1/4" Bolts
2 - Rear Brackets #42362-7	22 - 1/2" Flat Washers
1 - Driver Front Brace #42360-9	15 - 1/2" Lock Washers
1 - Pass. Front Brace #42360-10	15 - 1/2" Nuts
2 - Rear Brace #42360-11	8 - 3/8" T-bolts
1 - Bracket #42360-13	8 - 3/8" Flat Washers
1 - Bracket #42360-15	8 - 3/8" Lock Washers
1 - Brackets #42360-17	8 - 3/8" Nuts
8 - 1/2" T-bolts	8 - Plastic Washers
2 - Large Washers	
2 - M12-1.75 x 120mm Bolts	<b>*May include extra hardware.</b>

### **Note: Completely read instructions before beginning installation!**

1. Remove the contents from the box and check for missing pieces or damage. If parts are missing or damaged, contact the original place of purchase.
2. Locate the first set of openings in the rocker panel covered by tape or rubber plugs, as shown in **Diagram 2**. Insert (1) 3/8" T-bolt into each of the two holes in the rocker panel; and place one plastic washer on each bolt to prevent the T-bolt from falling into the rocker panel. Position (1) front bracket #42360-5 onto the T-bolts up against the rocker panel. Place (1) 3/8" flat washer, (1) 3/8" lock washer, and (1) 3/8" nut onto each T-bolt. Both driver and passenger side use brackets #42360-5 and install the same way. Hand tighten hardware to hold the brackets in place.
3. Remove the body mount bolts and factory metal washer located closest to the installed front brackets #42360-5, from previous step. Place (1) large washer onto the underside of the body mount. Using **Diagram 3** as a driver side reference, place brace #42360-9 from front bracket #42360-5 to the body mount. Insert (1) M12 x 120 mm Bolt through the brace and large washer threading into factory body mount. Use (1) 1/2" x 1 1/4" bolt with (2) 1/2" flat washers, (1) 1/2" lock washers and (1) 1/2" nuts to attach front brace #42360-9 to the front bracket #42360-5. Repeat the procedure for the passenger front brace #42360-10.

#### View of Front Passenger Rocker Panel

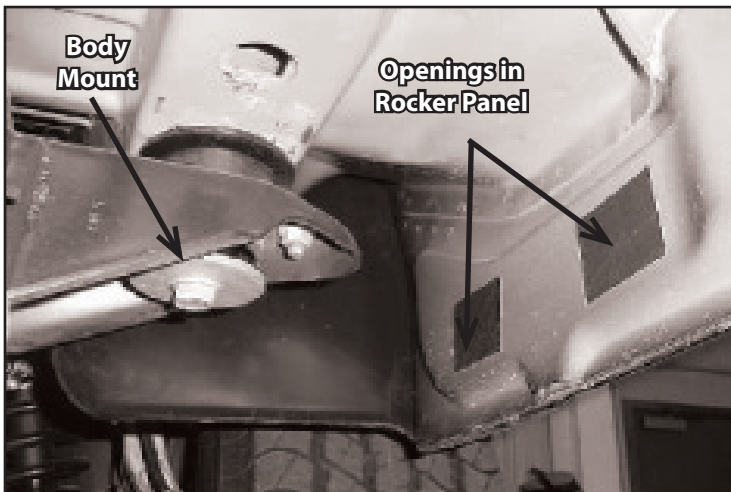

**Diagram 2**

#### View of Front Driver Bracket #42360-5 & Front Driver Brace #42360-9

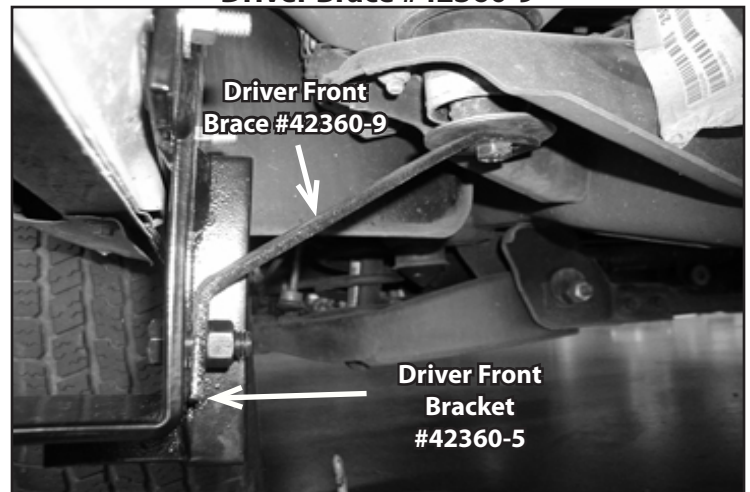

**Diagram 3**

420 N. Grove, Richardson, TX 75081  
 Tele: (800) 527 - 4345 Fax: (800) 442 - 5263  
 Web site: www.goindustries.com  
 E-mail: gosupport@goindustries.com

# Rancher Rugged Step

Installation Instructions

## 42362

Dodge Ram Mega Cab

1500 '06-'08

2500/3500 '06-'09

4. Locate the last set of openings in the rocker panel covered by tape or rubber plugs. Insert (1) 3/8" T-bolt into each of the two holes in the rocker panel; and place one plastic washer on each bolt to prevent the T-bolt from falling into the rocker panel. Position (1) rear bracket #42360-7 onto the T-bolts up against the rocker panel. Place (1) 3/8" flat washer, (1) 3/8" lock washer, and (1) 3/8" nut onto each T-bolt. Both Driver and Passenger side use bracket #42362-7 and install the same way. Hand tighten hardware to hold the brackets in place
5. The rear brace #42360-11 goes from the rear bracket #42362-7 to the frame on the passenger side. Use (1) 1/2" x 1 1/4" bolt with (2) 1/2" flat washers, (1) 1/2" lock washer and (1) 1/2" nut to attach the rear brace #42360-11 to rear bracket #42362-7 on the passenger side. Attach the other end of the rear brace #42360-11 to the hole in the side of the frame, using (1) 1/2" x 1 1/4" bolt with (2) 1/2" flat washers, (1) 1/2" lock washer and (1) 1/2" nut.
6. Assemble brackets #42360-13 and #42360-15 together as shown in **Diagram 4 and 5**, around the Driver side frame. Place (1) 1/2" flat washer onto the (1) 1/2" x 4" bolt and insert bolt through Bracket #42360-15, #42360-17, #42360-13 and connecting to bracket #42360-11, shown in **Diagram 4**. Install (1) 1/2" flat washer, (1) 1/2" lock washer, and (1) 1/2" nut on the bolt. Using (1) 1/2" bolt, (2) 1/2" flat washers, (1) 1/2" lock washer, and (1) 1/2" nut; connect bracket #42360-11 to bracket #42362-7.
7. Place the Rancher Rugged Step onto the brackets. Use the T-bolts from kit to attach the Rancher Rugged Steps to the brackets, see **Diagram 6**. Place the T-bolt down through the slats in the Rancher Rugged Steps into the holes in the brackets. Place (1) 1/2" flat washer, (1) 1/2" Lock Washer and (1) 1/2" nut onto T-bolts.
8. Tighten brackets to truck first then tighten all T-bolts. **Do not use a pneumatic impact to tighten hardware.**

**Driver Side Rear Brackets Viewed from Behind Truck Cab, Looking Forward.**

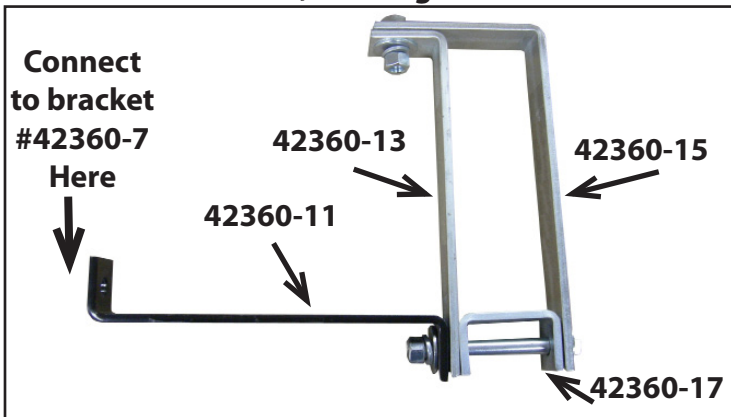

**Diagram 4**

**Bracket #42360-11 Attached, Viewed from Behind Truck Cab, Looking Forward.**



**Diagram 5**

**View of T-bolts**

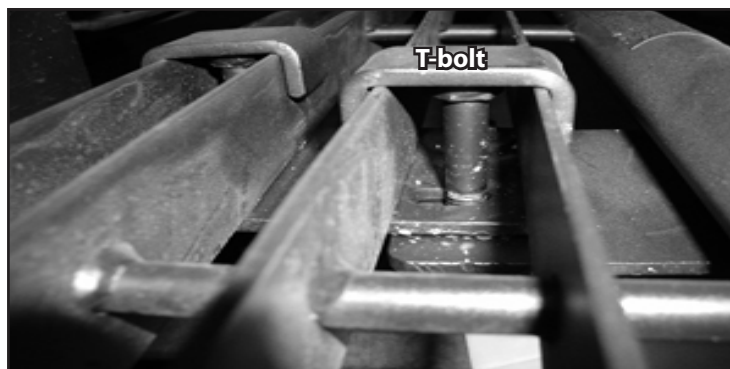

**Diagram 6**